

Product Features:



- Input voltage range: 90~305Vac.
- Constant current design.
- Output current adjustable by built-in potentiometer.
- THD<10%.
- 3-in-1 dimmable: 0~10Vdc, PWM, Resistance.
- 0-10V reverse dimming is optional.
- Output and Dimming signal isolating, dim to off.
- Standby power consumption ≤0.5W.
- Surge protection: 4KV DM, 6KV CM.
- Protections: Output OVP, SCP.
- IP65 design for indoor and outdoor applications.
- Suitable for dry / damp / wet locations.
- 5 years warranty.

Application:

- Suitable for LED roadway lighting, industrial lighting, landscape lighting, etc.

DESCRIPTION

The X6-36W is a 36W, constant-current, IP65 LED driver that operates from 90-305Vac input with excellent power factor and low THD. It is created for industrial lights, tunnel and street lights. The high efficiency of these drivers and compact metal case enable them to run cooler, significantly improving reliability and extending product life. To ensure trouble-free operation, protection is provided against input surge, output over voltage, and short circuit.

MODELS

Model Number[1]	Input voltage range(Vac)	Max Output Power (W)	Output Voltage Range (Vdc)	Output Current Adjustable Range (A)	Default Output	Typical Efficiency	Typical THD	Typical PF	
								120Vac	230Vac
X6-036Y052L	90-305	36	28-52	0.4-0.8	28-45V/0.80A	88%	10%	0.99	0.96

Notes:

[1]. Y can be M or V. Y=V means non-dimmable, Y=M, means 3-in-1 dimmable. model-A Indicates forward dimming; model-B Indicates reverse dimming.

[2]. All specifications are measured at 25°C ambient temperature, input voltage 230Vac, and the typical value tested by full load, if no specific note.

OPERATING AREA I-V

X6-036Y052L

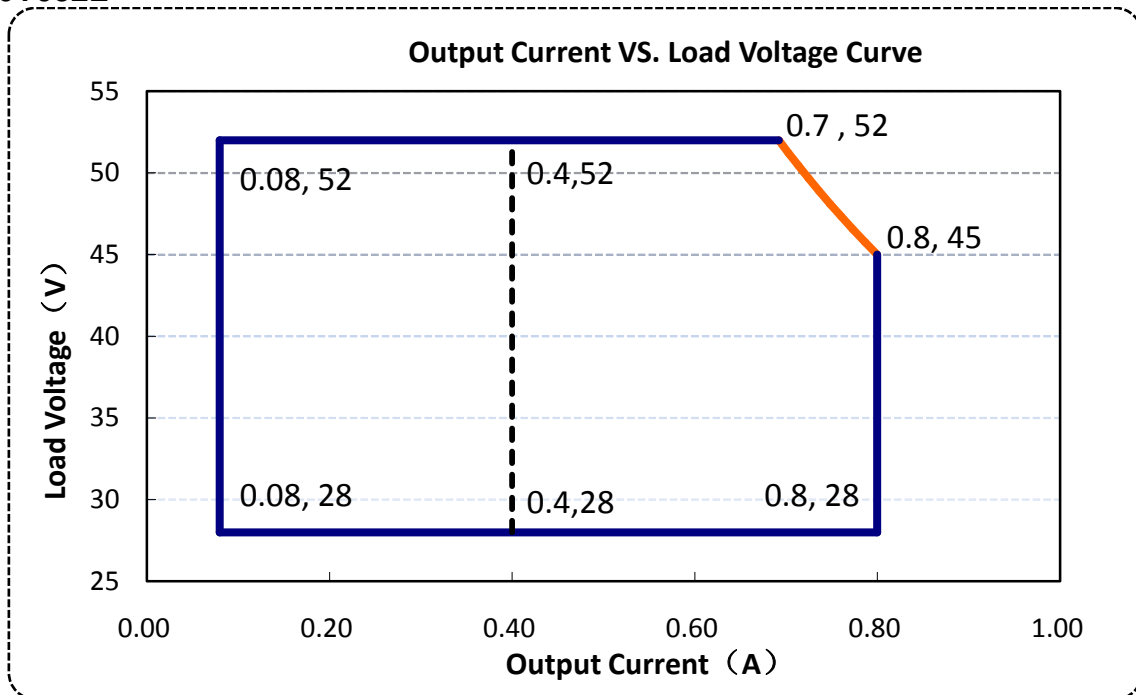

Notes:

The drivers are not allowed to work in over-load condition, otherwise warranty will expire.

Y=V is suitable for the right area of the dotted line; Y=M is suitable for the solid line contain area.

INPUT SPECIFICATIONS

Parameter	Min.	Typ.	Max.	Notes			
Input Voltage	90Vac	100-277Vac	305Vac				
Input Frequency	47Hz	50/60	63Hz				
Leakage Current	-	-	0.75mA	277Vac/60Hz			
Input AC Current	-	-	0.5A	100-277Vac & full load			
Inrush Current	-	-	0.15A ² S	230Vac input, Ta=25°C (cold start)			
Power Factor	0.97	0.99	-	120Vac, 50-60Hz, full load			
	0.95	0.96	-	230Vac, 50-60Hz, full load			
	0.90	0.92	-	277Vac, 50-60Hz, full load			
THD	-	5%	10%	100-240Vac, 50-60Hz, 70%-100% load			
	-	-	15%	277Vac, 50-60Hz, 70%-100% load			
Max. NO. of PSUs on CIRCUIT BREAKER	B10	16	B16	25	B25	39	230Vac, full load
	C10	26	C16	41	C25	65	

OUTPUT SPECIFICATIONS

Parameter	Min.	Typ.	Max.	Notes
Output Current Tolerance	-8%	-	8%	
Output Current Setting Range (A) X6-036Y052L	0.40	-	0.80	
Total Output Current Ripple(pk-pk)	-	150%	200%	20MHz BW, full load& LED load, the ripple would be tiny different under different LED load.
Startup Overshoot Current	-	5%	10%	100~277Vac & 100% Load, load is LED
No Load Output Voltage(V) X6-036Y052L	-	-	70	
Line Regulation	-3%	-	+3%	25°C±10°C ambient temperature, input voltage changes from 100Vac to 277Vac.
Load Regulation	-5%	-	+5%	25°C±10°C ambient temperature, Input Voltage 230Vac, load changes from 60% to 100%.
Turn-on Delay Time	-	-	3S	120Vac, 100% load
	-	0.5S	1S	230Vac, 100% load
Standby Power Consumption	-	-	0.5W	230Vac/50Hz, Dim to off

GENERAL SPECIFICATIONS

Parameter	Min.	Typ.	Max.	Notes
Efficiency @120Vac X6-036Y052L	86%	87%		Measured at full load and 25°C ambient temperature
Efficiency @230Vac X6-036Y052L	87%	88%		Measured at full load and 25°C ambient temperature
Efficiency @277Vac X6-036Y052L	87%	88%		Measured at full load and 25°C ambient temperature
Dielectric Strength	Input-Output	3750Vac	-	Max 5mA/60S
	Input-PE	1875Vac	-	
	Output-PE	1600Vac	-	
Grounding Resistance	-	-	0.1Ω	25A/60S, under 25°C±10°C ambient temperature
Insulation Resistance	10MΩ	-	-	Input-Output, Input-PE, Output-PE, 500Vdc/60S/25°C/70%RH
MTBF	-	200000 hours	-	25°C±10°C ambient temperature, 230Vac, 80% load (MIL-HDBK-217F)
Lifetime	-	50000 hours	-	230Vac&100% load, 75°C case temperature, refer to lifetime curve for details
Ambient Temperature	-40°C	-	+60°C	
Operating Case Temperature for Safety Tc_s	-40°C	-	+85°C	
Operating Case Temperature for Warranty Tc_s	-40°C	-	+75°C	5 years warranty case temperature Humidity: 10% to 95% RH
Storage Temperature	-40°C	-	+85°C	Humidity: 5% to 100% RH
Dimensions (L*W*H)mm	L119*W65*H34			
Net Weight	470± 50g/PCS			
Package	L424mm*W354mm*H146mm; 12PCS/Ctn, Gross Weight: 6.24Kg			

DIMMING

Parameter		Min.	Typ.	Max.	Notes
0~10V Absolute Maximum Voltage on the Vdim (+) Pin		-	10V	15V	
0~10V Source Current on Vdim(+)Pin		-	100uA	200uA	
Dimming Output Range	X6-060M052L	10%Imax	-	100%Imax	I _{max} =0.80A
Recommended Dimming Range for 0-10V		0V	-	10V	Default 0-10V/ PWM Dimming
PWM_in High Level		9.7V	-	10.3V	
PWM_in Low Level		0V	-	0.3V	
PWM_in Frequency Range		300Hz		2KHz	
PWM_in Duty Cycle		1%	-	99%	

SAFETY STANDARDS

Safety Category	Country / Territory	Standards	Approved
CCC	China	GB19510.1, GB19510.14	√
CE	Europe	EN61347-1, EN61347-2-13	√
		EN62493	√
ENEC		EN62384	
CB	CB Countries	IEC61347-1, IEC61347-2-13	√
BIS	India	IS 15885(PART 2/SEC 13)	
UL	USA	UL 8750	
CUL	Canada	CSA C22.2 No.250.13	
KC	South Korea	K61347-1, K61347-2-13	
PSE	Japan	J61347-1, J61347-2-13	
SAA	Australia	AS/NZS IEC 61347.2.13	
		AS/NZS 61347.1	

EMC COMPLIANCE

EMC Category	Country / Territory	Standards	Approved
CCC	China	GB/T 17743, GB 17625.1	√
CE	Europe	EN 55015	√
		EN 61000-3-2, EN 61000-3-3	√
		EN61000-4-2,3,4,5,6,11	√
		EN 61547	√
KC	South Korea	K61547	
		K00015	
PSE	Japan	J55015	
FCC	USA	FCC part 15	

NOTE:

This LED driver meets the EMI specifications above, but as a component of a luminaire, end customer need to identify the EMI performance of a luminaire including LED driver, other devices connected to the driver and on the luminaire itself.

INRUSH CURRENT WAVEFORM

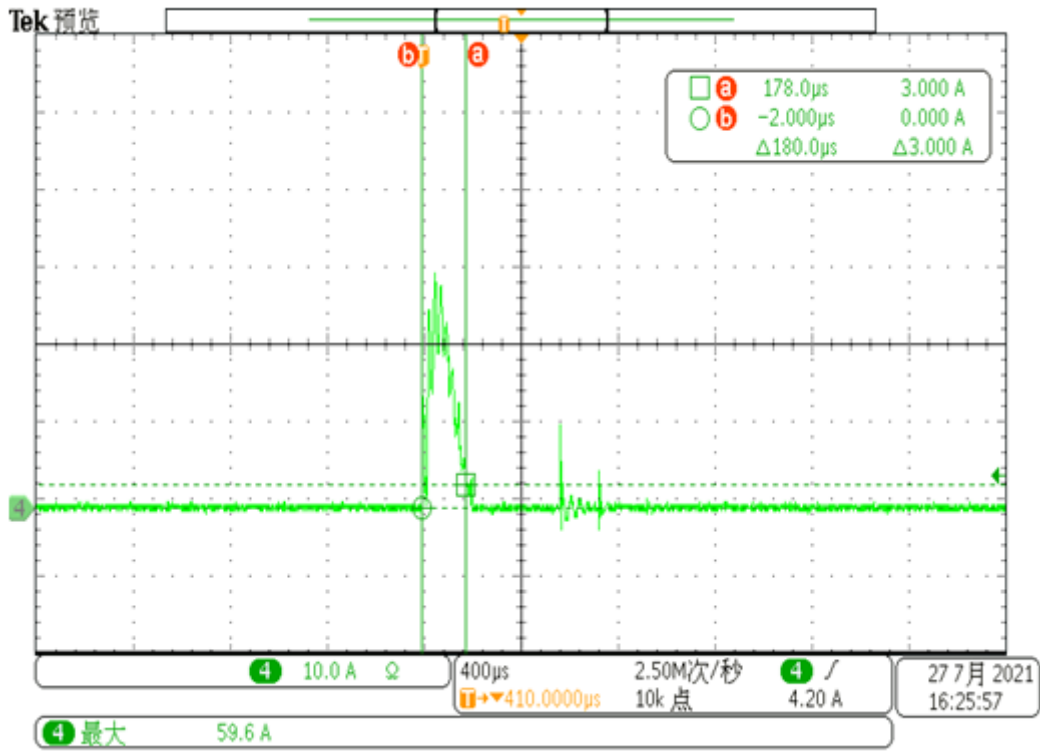

DERATING CURVE

Derating Curve

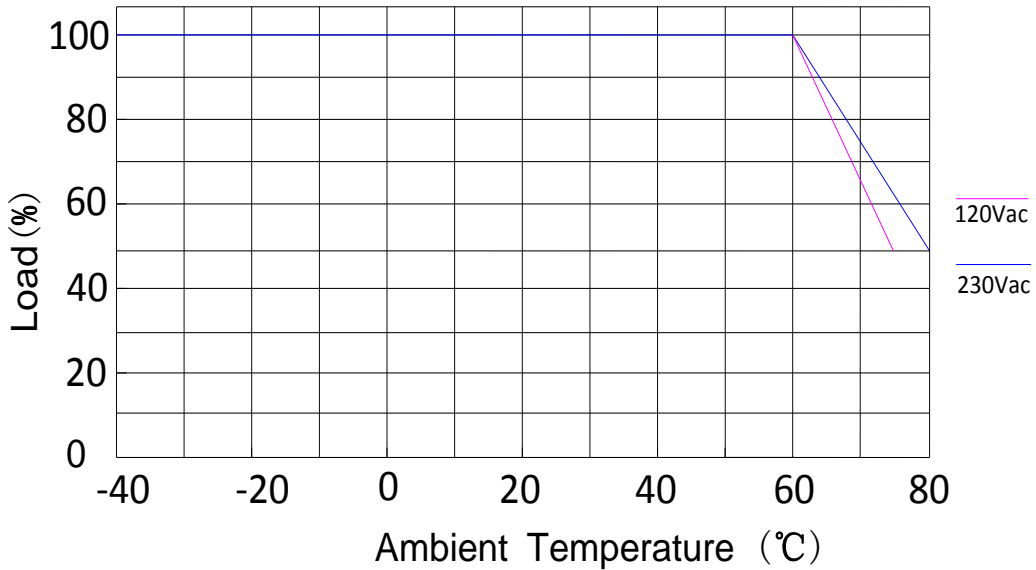

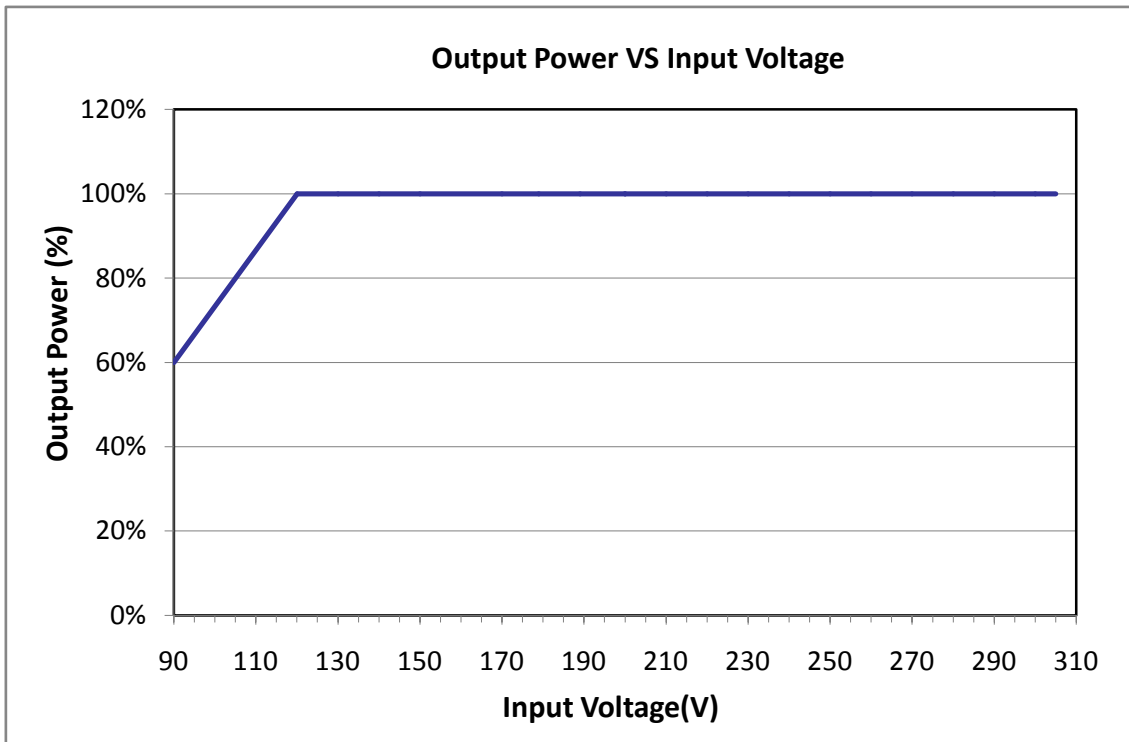
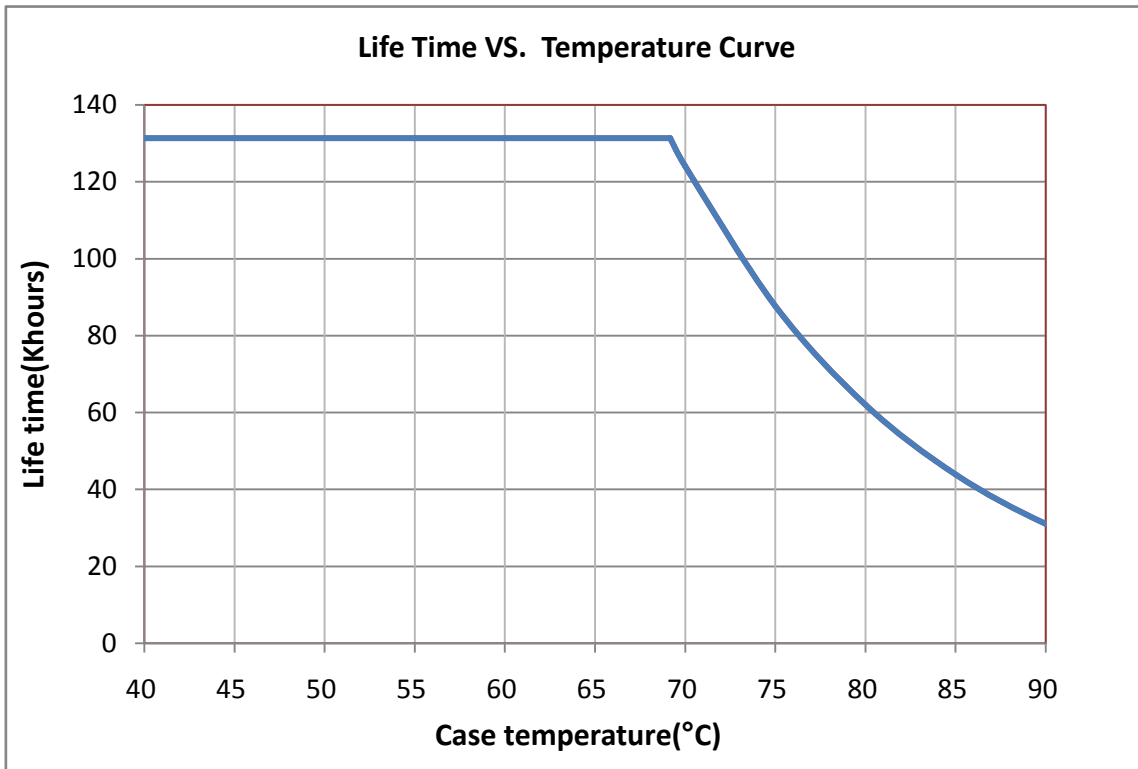
OUTPUT POWER VS INPUT VOLTAGE**LIFETIME VS CASE TEMPERATURE**

EFFICIENCY VS LOAD

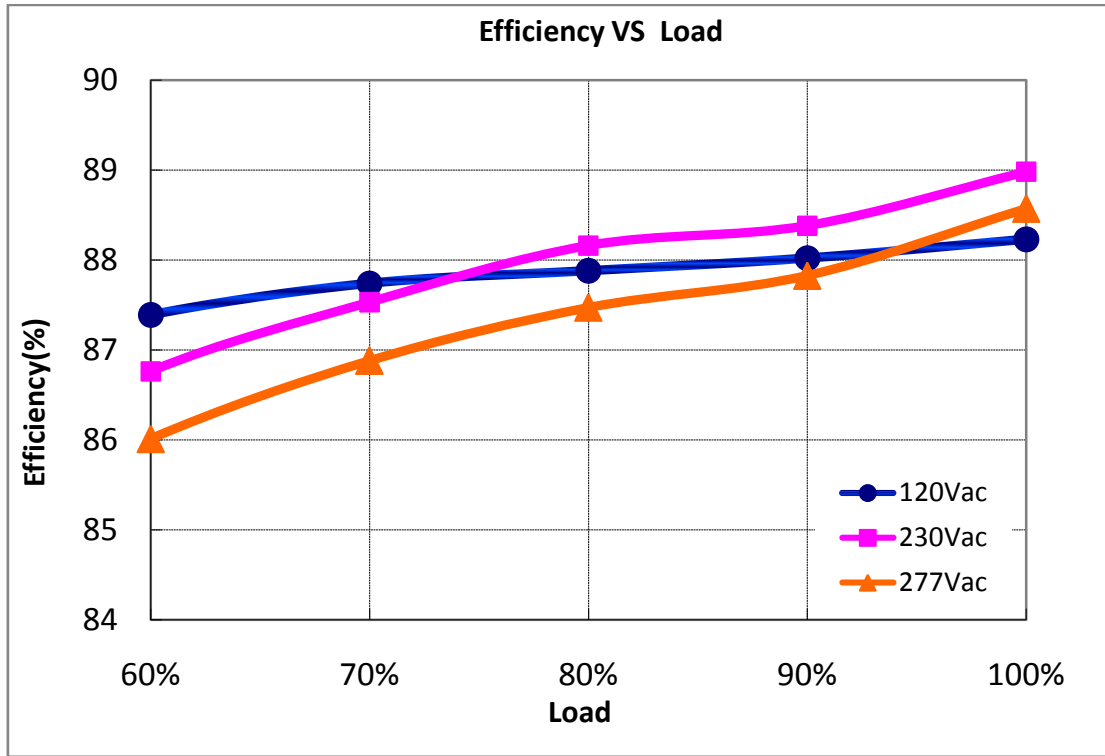

POWER FACTOR VS LOAD

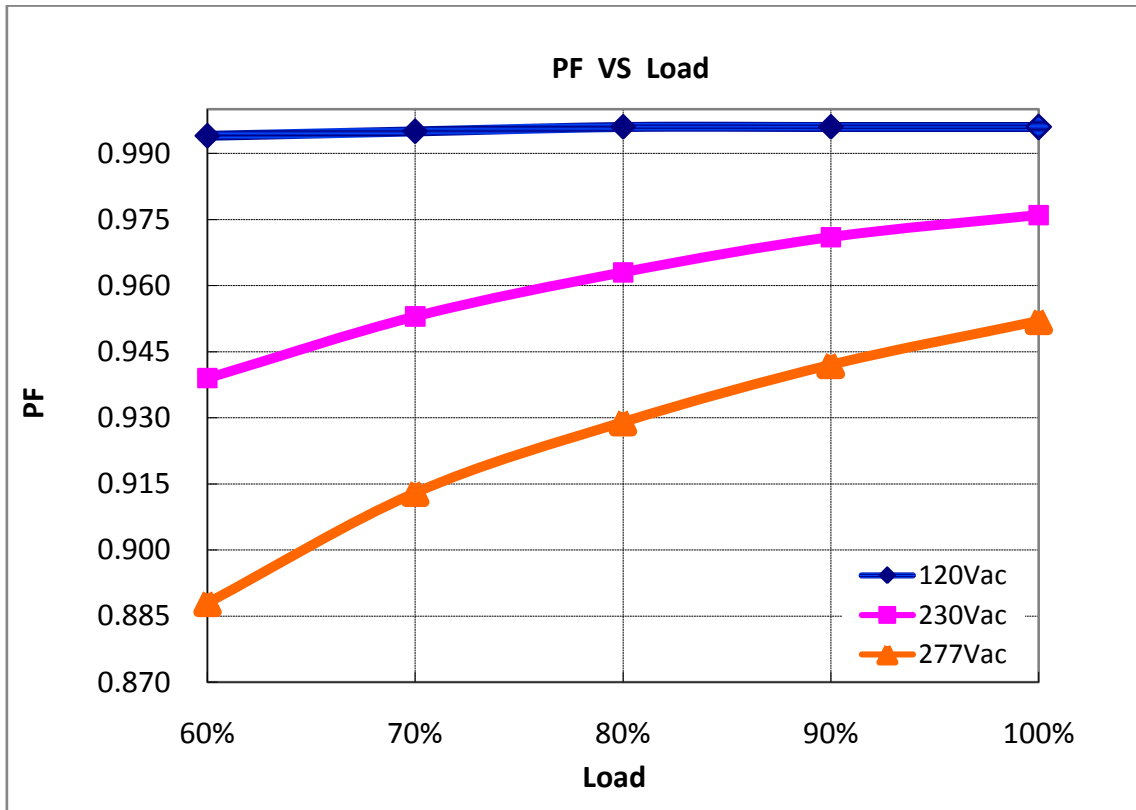

TOTAL HARMONIC DISTORTION

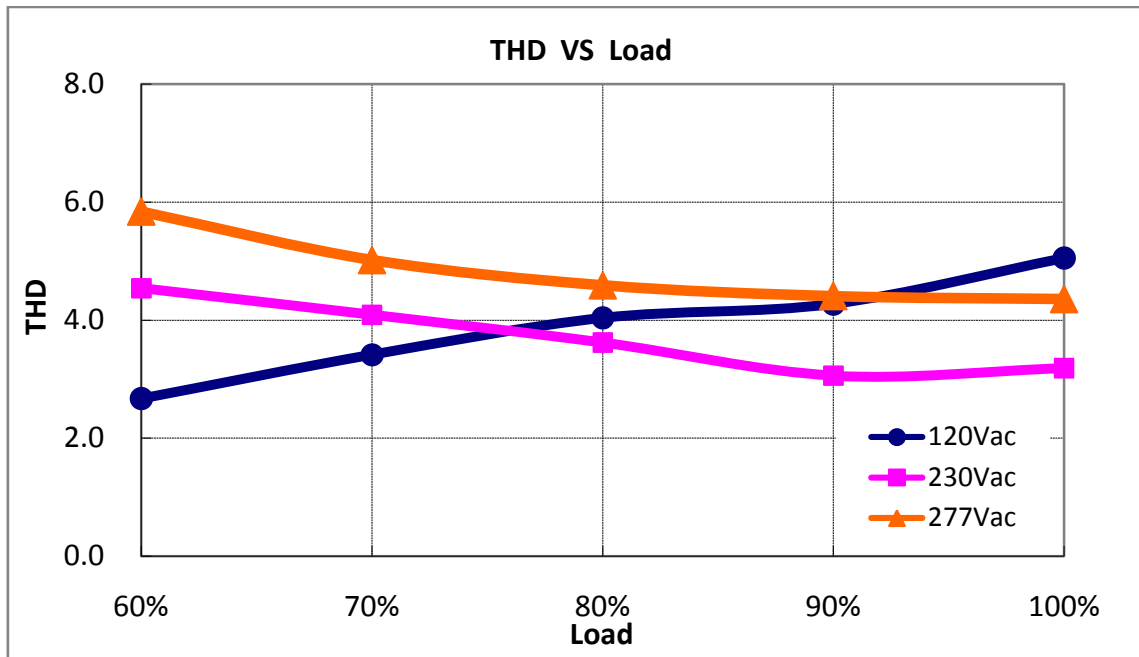

0-10V/PWM DIMMING

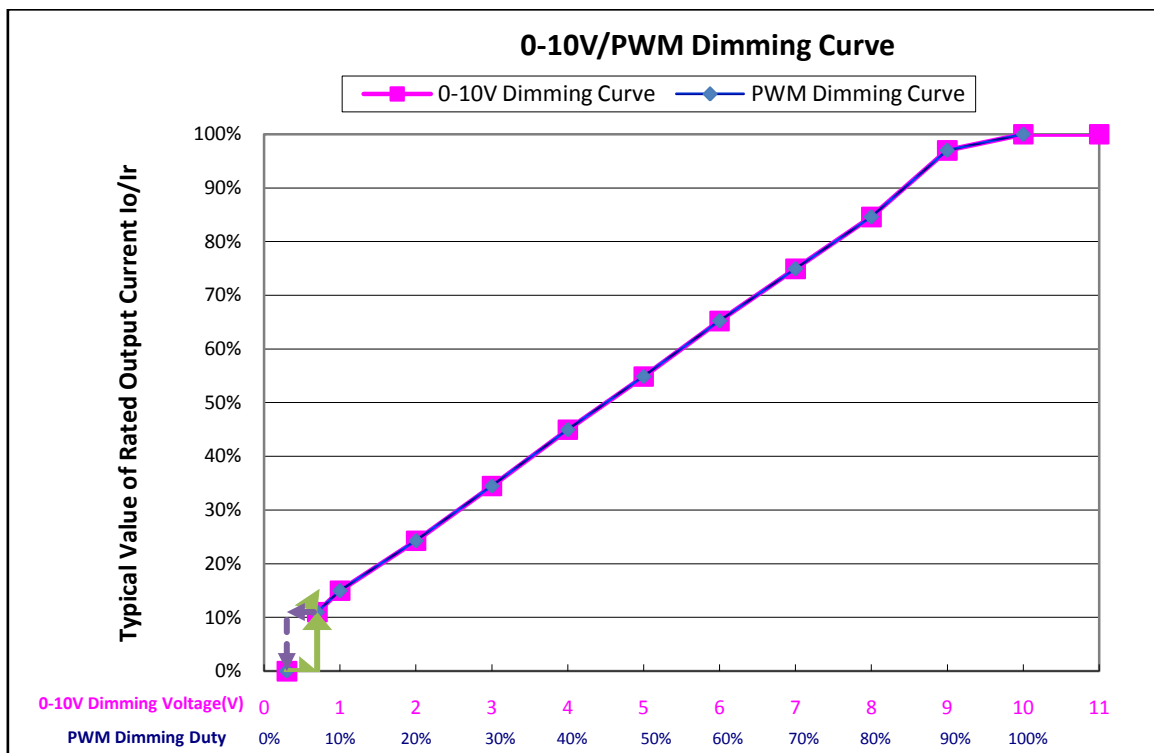

PROTECTIONS

Parameter	Notes
Output Over Voltage Protection	Limits output voltage at no load and in case the normal voltage limit fail
Short Circuit Protection	Hiccup mode and auto recovery. No damage will occur when any output is short circuited. The output shall return to normal when the fault condition is removed.

MECHANICAL OUTLINE

X6-036M052L

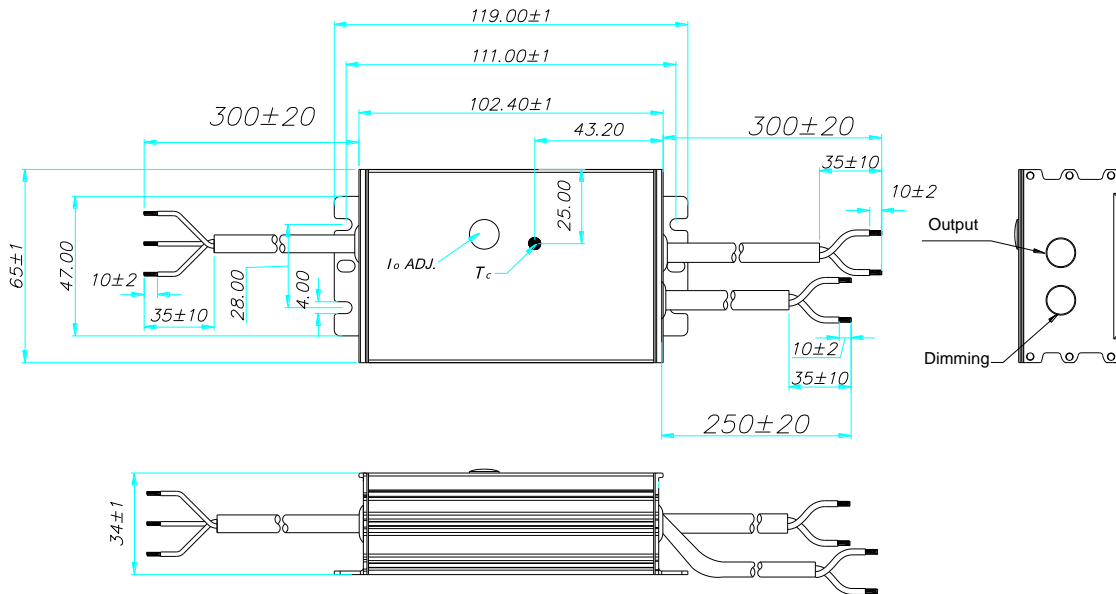

X6-036V052L

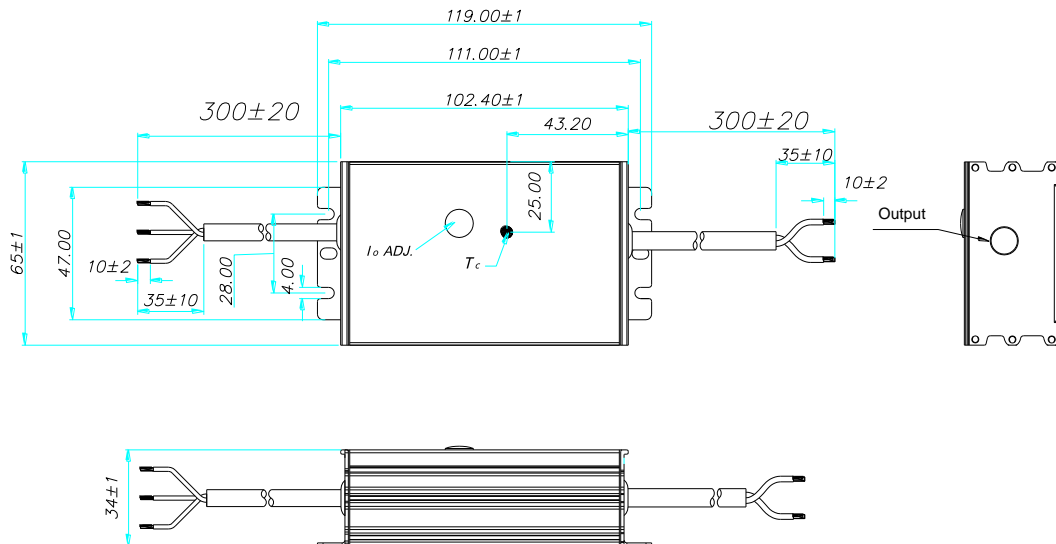

Wire	Specification	Note
Input	17AWG*3C SJOW external diameter: 7.3mm L=300±20mm, peel length 35mm, Tin-dip length 10mm	for CCC/CE
Output	17AWG*2C SJOW external diameter: 6.9mm L=300±20mm, peel length 35mm, Tin-dip length 10mm	for CCC/CE
Dimming	UL2733 22AWG*2C external diameter: 5.45mm L=250±20mm, peel length 50mm, Tin-dip 4mm	Y=M